

TEXAS PNEUMATIC TOOLS, INC.

Service, Operation AND Parts Manual

IN-LINE LUBRICATOR

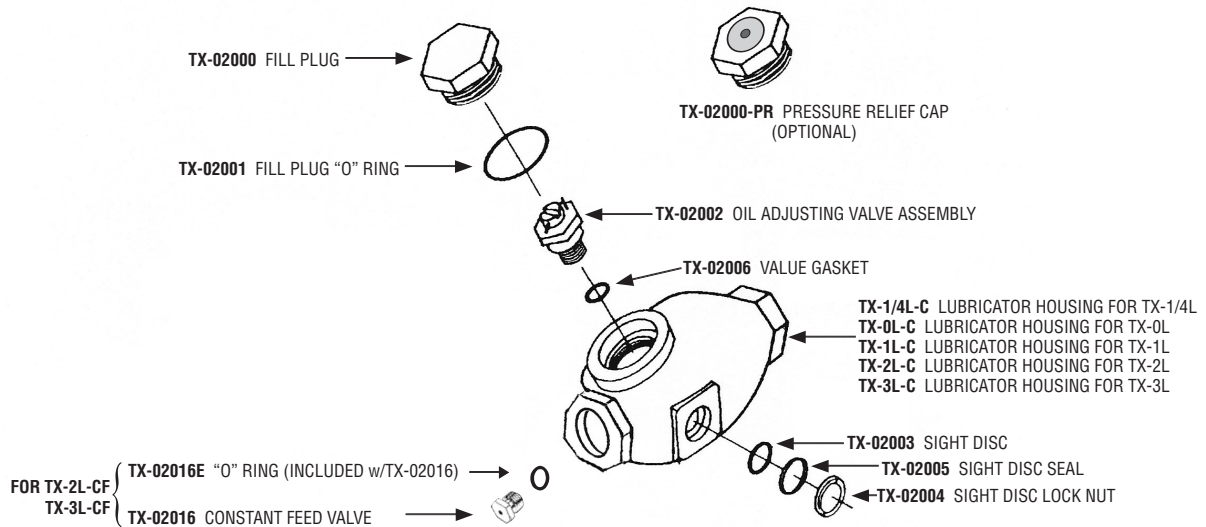

TOOL SPECIFICATIONS

| MODEL NUMBER | OIL CAPACITY | AIR FLOW CAPACITY | INLET / OUTLET THREAD SIZE (*) | MAXIMUM WORKING PRESSURE | RECOMMENDED OIL WEIGHT |
|--------------|-----------------------------|-------------------------|--------------------------------|--------------------------|------------------------|
| TX-1/4L | 1.05 fl. oz. 29.8 grams | 25 CFM 707.9 l/min | 1/4" NPT 6.4 mm | 500 psi 34.5 BAR | 5 - 10 WT. |
| TX-0L | 1.4 fl. oz. 104.9 grams | 30 CFM 849.5 l/min | 1/2" NPT 12.7 mm | 500 psi 34.5 BAR | 5 - 10 WT |
| TX-1L | 3.7 fl. oz. 104.9 grams | 70 CFM 1982.2 l/min | 3/4" NPT 19.1 mm | 260 psi 17.9 BAR | 5 - 10 WT. |
| TX-2L (**) | 11.0 fl. oz. 311.8 grams | 70 CFM 1982.2 l/min | 3/4" NPT 19.1 mm | 300 psi 20.7 BAR | 5 - 10 WT. |
| TX-3L (**) | 16.0 fl. oz. 453.6 grams | 150 CFM 4247.5 l/min | 1" NPT 25.4 mm | 250 psi 17.2 BAR | 5 - 10 WT. |

DESCRIPTION: These are heavy duty in-line lubricators to be installed in air line within 6-8 feet of tool. Rugged construction will allow dragging on floor or ground behind tool. Designed for use with tools being used too far away from compressor to be lubricated by a permanently mounted unit. (*) British Standard Thread (BSP) also available. Nickle Plate (NP) option available. (**) Available with constant feed valve.

INSTALLATION: Most effective installation is about 6 feet from tool. On new hose whip installation, pour 1/2 ounce of oil directly in hose to coat with lubricant, so tool will not run dry while hose is being coated.

ADJUSTMENT: At the bottom of the oil reservoir is an oil adjusting valve assembly. Remove the filler cap to adjust. The brass metering valve can easily be adjusted with a screwdriver. A setting of 5 to 10 is suitable for most applications, but viscosity, pressure, and compressed air flow (CFM) all determine oil usage, so experience based on usage will be your best guide.

~ Made in U.S.A. ~

www.airtools.com

Email: tptinfo@airtools.com

TEXAS
1-800-231-9740
254-587-2533 (Int'l calls)

NEVADA
1-800-858-1222

VIRGINIA
1-800-626-1091

Hose Whip Assemblies with Lubricators

| PART # | COUPLING + LUBRICATOR + 6' HOSE + CONNECTOR |
|--------------------|--|
| TX-1HW | Crowfoot + TX-0L + 6' 300 PSI, 1/2" ID Hose + 1/4" MPT |
| TX-2HW | Crowfoot + TX-0L + 6' 300 PSI, 1/2" ID Hose + 3/8" MPT |
| TX-3HW | Crowfoot + TX-0L + 6' 300 PSI, 1/2" ID Hose + 1/2" MPT |
| TX-4HW | Crowfoot + TX-0L + 6' 300 PSI, 1/2" ID Hose + 7/8" -24 Thread Hose Swivel (TX-01087) |
| TX-4HW-1/2 | Crowfoot + TX-0L + 6' 300 PSI, 1/2" ID Hose + 1/2" MPT Bent Swivel (TX-00988) |
| TX-5HW | Crowfoot + TX-1L + 6' 300 PSI, 1/2" ID Hose + 3/8" MPT |
| TX-6HW | Crowfoot + TX-1L + 6' 300 PSI, 1/2" ID Hose + 1/2" MPT |
| TX-7HW | Crowfoot + TX-1L + 6' 300 PSI, 1/2" ID Hose + 3/4" MPT |
| TX-8HW | Crowfoot + TX-1L + 6' 300 PSI, 1/2" ID Hose + 7/8" -24 Thread Hose Swivel (TX-01087) |
| TX-8HW-1/2 | Crowfoot + TX-1L + 6' 300 PSI, 1/2" ID Hose + 1/2" MPT Bent Swivel (TX-00988) |
| TX-9HW | Crowfoot + TX-1L + 6' 300 PSI, 1/2" ID Hose + Crowfoot Hose End |
| TX-10HW | Crowfoot + TX-2L + 6' 300 PSI, 1/2" ID Hose + Crowfoot Hose End |
| TX-11HW | Crowfoot + TX-2L + 6' 300 PSI, 1/2" ID Hose + 1/2" MPT |
| TX-12HW | Crowfoot + TX-2L + 6' 300 PSI, 3/4" ID Hose + 3/4" MPT |
| TX-12HW-1/2 | Crowfoot + TX-2L + 6' 300 PSI, 3/4" ID Hose + 1/2" MPT |
| TX-15HW | Crowfoot + TX-3L + 6' 300 PSI, 3/4" ID Hose + Crowfoot Hose End |

Many more combinations with different hose types, hose lengths and hose connectors available.
Hose types include Gorilla hose (500 psi), Hercules hose (1,000 psi) and Hydraulic hose (2,000 psi).
Hose lengths in excess of 10 feet are not recommended.

Preparing For Operation

Percussion tools create constant vibration when in use. Scalers, chipping hammers, rivet busters, paving breakers, rock drills, etc., should not be directly connected to the compressed air line with quick disconnect couplings. Vibrations cause an inherent danger of having the quick disconnect couplings come loose from the tool. Severe injury could result from an erratic hose swinging about due to the releasing air pressure. Hose whip assemblies help avoid this situation. The hose end of the assembly is screwed directly to the inlet of the tool. The quick disconnect coupling (hose connector) is screwed into the lubricator which is six feet from the tool. This distance allows the operator some room if the coupling were to become disconnected while under pressure. The use of safety lock cables (TX-SLC1 or TX-SLC2) should be used on all hose connectors. A safety lock cable protects the operator by minimizing the amount of travel for an erratic hose.

Before filling the lubricator with oil, it is necessary to disconnect the air line. If the lubricator has been pressurized, the oil reservoir will depressurize while the Fill Plug (TX-02000) is being unscrewed. The optional Pressure Relief Cap (TX-02000-PR) will allow depressurization of the reservoir by simply pressing the button before removing. Fill the lubricator and screw the Fill Plug back into place. For storage, it is necessary to depressurize the reservoir or oil will continue to flow through the valve until the pressure equalizes.

Pressure Feed Lubricators

When the oil reservoir of the lubricator is filled, and the air line is pressurized (approximately 90 psi), a portion of the pressurized air will reverse through the Oil Adjusting Valve Assembly (TX-02002) and pressurize the oil reservoir. At this point, the air line and oil reservoir have the same pressure. When the tool is activated, there is a slight pressure drop in the air line leading to the tool. The pressure differential between the air line and the oil reservoir will allow the oil to flow through the Oil Adjusting Valve Assembly. Once the oil contacts the air moving towards the tool, it will atomize and lubricate the tool. It is necessary to stop the tool occasionally to allow the air pressure to re-pressurize the oil reservoir. Most air tools are turned on and off frequently. Therefore, pressure feed lubricators are most often used with air tools.

Air tools such as rock drills, air pumps, and air motors that run for extended periods (more than 30 minutes) without turning off, should use Constant Feed Lubricators.

Constant Feed Lubricators

When air tools run for extended periods, the pressure in the oil reservoir of a pressure feed lubricator will equalize with the pressure in the air line. The pressure equalization will not allow oil to flow through the Oil Adjusting Valve Assembly. Constant Feed Lubricators have a check valve (TX-02016) that allows compressed air from the air line to continually pressurize the oil reservoir which in turn continually supplies oil to the air moving towards the tool. Since tools such as rock drills, air pumps and air motors generally use large amounts of oil, Constant Feed Lubricators are only available as TX-2L-CF and TX-3L-CF models.